

DB3 FA



DB3 FA Automatic bun divider rounder

The DB3 FA automatic bun divider rounders work with oscillating plates and are suitable for dividing and rounding any kind of dough without damaging the leavening process, in order to obtain round buns of variable weight. Perfectly rounded portions can be obtained thanks to the completely automatic work cycle and the possibility to adjust electronically pressure time and strength, depending on dough type.

Features

- Completely automatic model.
- Painted steel structure mounted on wheels.
- Interchangeable dividing and moulding unit with aluminium structure, Teflon-coated outer surface, stainless steel blades
- Three interchangeable rounding plates made of non-toxic material.
- Plate supporting top made of aluminium.
- Ultra-silent hydraulic system for cutting, pressing and rounding.
- Electronic control panel, possibility to memorize up to 5 work cycles.
- Electrical power supply: V. 400/3/50Hz (different voltages on request).
-

Accessories

- Additional plastic rounding plates.

This machine complies  regulations.

MODEL	Description	Price €
DB3 FA 14-4	Model with 14 piece capacity - approx. dough portion weight from gr. 130 to gr. 250. ** Approx. hourly output: 1200 pieces/hour.	
DB3 FA 30-3	Model with 30 piece capacity - approx. dough portion weight from gr. 30 to gr. 100. ** Approx. hourly output: 2400 pieces/hour.	
DB3 FA 30-4	Model with 30 piece capacity - approx. dough portion weight from gr. 40 to gr. 130. ** Approx. hourly output: 2400 pieces/hour.	
DB3 FA 36-4	Model with 36 piece capacity - approx. dough portion weight from gr. 30 to gr. 110. ** Approx. hourly output: 2800 pieces/hour.	
DB3 FA 52-3	Model with 52 piece capacity - approx. dough portion weight from gr. 20 to gr. 50.** Approx. hourly output: 4000 pieces/hour.	

**N.b.: minimum and maximum weights are approximate and can change according to dough leavening degree.

ACCESSORIES

14-4	Plastic rounding plate
30-3	Plastic rounding plate
30-4	Plastic rounding plate
36-4	Plastic rounding plate
52-3	Plastic rounding plate

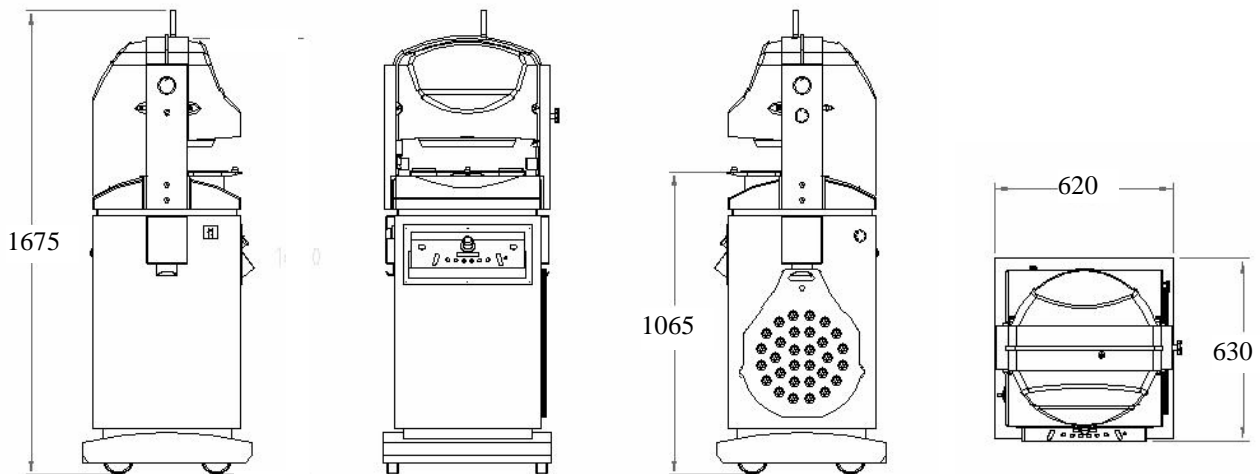

Technical specifications

Model	DB3 FA 14-4	DB3 FA 30-3	DB3 FA 30-4	DB3 FA 36-4	DB3 FA 52-3
Power (kw)	1.3	1.3	1.3	1.3 kW	1.3
Dimensions and weights					
Loading height (mm)	1065	1065	1065	1065 mm	1065
Overall (mm)	620 x 630	620 x 630	620 x 630	620 x 630 mm	620 x 630
Height (mm)	1675	1675	1675	1675 mm	1675
Net weight (kg)	380	380	380	380	380
Packing					
Pallet	Width (mm)	750	750	750	750
	Length (mm)	750	750	750	750
	Height (mm)	1890	1890	1890	1890
	Weight (kg)	400	400	400	400